

SLP-24-400 Series: 2.4 VA Standard Profile PC Mount Power transformers with a single 24V primary and dual secondaries for Domestic Instrumentation and HVAC power applications. Split bobbin construction provides excellent primary to secondary isolation.

- Dielectric Strength - 2500Vrms Hipot primary to secondary
- Primary - Single Primary 24V, 60Hz
- Dual secondaries - Series or Parallel
- UL Recognized CLASS B (130°C) Insulation system, UL 1446 (File E85315)
- Three flange bobbin design, no electrostatic shield required
- 100% Final Tested: Every single transformer is tested on automated panels for exciting current, open circuit voltage (turns ratio), polarity (phasing) and dielectric strength
- Immersed in 100% solids epoxy resin to withstand most aqueous and solvent cleaning systems
- Other primary and secondary voltages may be custom designed to your specifications
- Pin-out compatible with 115V SPW-400-S series

All dimensions for reference only. [ ]=mm

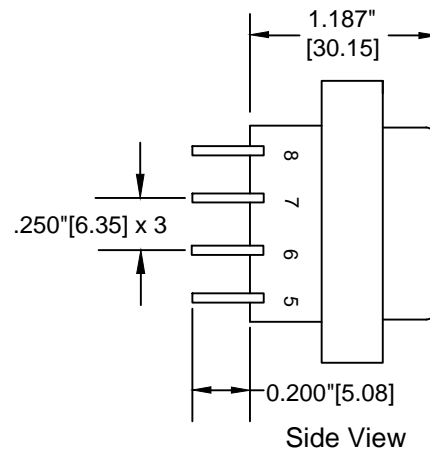
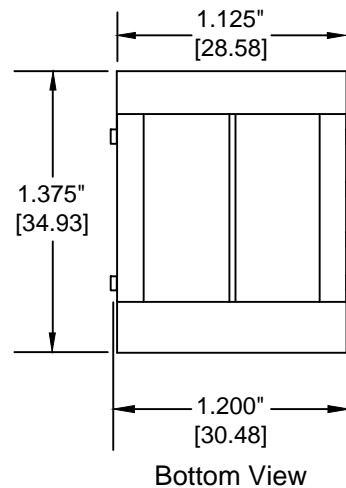
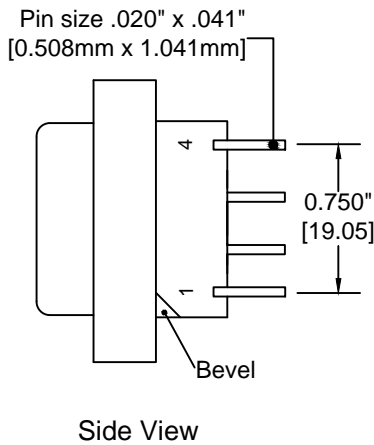

SECONDARY WINDINGS ARE DESIGNED TO BE USED AS ONE SECONDARY WINDING WITH EITHER PARALLEL OR SERIES CONNECTIONS ONLY!

Schematic

INPUT VOLTAGE 1 - 4 ; 24V, 60Hz

SECONDARY PARALLEL CONNECTIONS:  
TIE 5-7, 6-8; OUTPUT 5-8

SECONDARY SERIES CONNECTIONS:  
TIE 6-7; OUTPUT 5-8

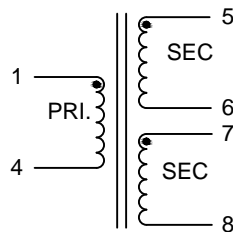

Note: Pins 2 & 3 omitted  
• Dots indicate like polarity

RMS RATING WITH SECONDARIES CONNECTED IN:

Part Number	VA	Series	Parallel
SLP-24-400	2.4	10Vct@250mA	5V@500mA
SLP-24-401	2.4	12.6Vct@200mA	6.3V@400mA
SLP-24-402	2.4	16Vct@150mA	8V@300mA
SLP-24-403	2.4	20Vct@120mA	10V@240mA
SLP-24-404	2.4	24Vct@100mA	12V@200mA
SLP-24-405	2.4	28Vct@85mA	14V@170mA

## SLP-24-400- Series

### Notes

FUSING THE TRANSFORMER TO MEET SAFETY AGENCY REQUIREMENTS IS THE RESPONSIBILITY OF THE CUSTOMER.

# PREM

MAGNETICS INCORPORATED  
3521 N. CHAPEL HILL RD.  
JOHNSBURG, IL 60051

PREM PART  
SLP-24-400 SERIES  
PC MOUNT

Approved: R Randow

Scale: None

Date: 03/18/2015